

FORM A: BID
(See B8)

1. Contract Title REMOUNTING OF SANDER SPREADER BODIES

2. Bidder

Name of Bidder

Usual Business Name of Bidder as it appears on Invoice (if different from above)

Street

City

Province

Postal Code

Email Address of Bidder

Facsimile Number

(Mailing address if different)

Street or P.O. Box

City

Province

Postal Code

GST Registration Number (if applicable)

The Bidder is:

(Choose one)

a sole proprietor

a partnership

a corporation

carrying on business under the above name.

3. Contact Person

The Bidder hereby authorizes the following contact person to represent the Bidder for purposes of the Bid.

Contact Person

Title

Telephone Number

Facsimile Number

Email Address

4. Definitions

All capitalized terms used in the Contract shall have the meanings ascribed to them in the General Conditions and D3.

5. Offer The Bidder hereby offers to perform the Work in accordance with the Contract for the price(s), in Canadian funds, set out on Form B: Prices, appended hereto.

6. Commencement of the Work The Bidder agrees that no Work shall commence until he/she is in receipt of a notice of award from the Award Authority authorizing the commencement of the Work.

7. Contract The Bidder agrees that the Bid Opportunity in its entirety shall be deemed to be incorporated in and to form a part of this offer notwithstanding that not all parts thereof are necessarily attached to or accompany this Bid.

8. Addenda The Bidder certifies that the following addenda have been received and agrees that they shall be deemed to form a part of the Contract:

No.	Dated
_____	_____
_____	_____
_____	_____

9. Time This offer shall be open for acceptance, binding and irrevocable for a period of sixty (60) Calendar Days following the Submission Deadline.

10. Signatures The Bidder or the Bidder's authorized official or officials have signed this _____ day of _____, 20_____.

Signature of Bidder or
Bidder's Authorized Official or Officials

(Print here name and official capacity of individual whose signature appears above)

(Print here name and official capacity of individual whose signature appears above)

FORM B: PRICES
(See B9)

REMOUNTING OF SANDER SPREADER BODIES

UNIT PRICES

ITEM NO.	DESCRIPTION	SPEC. REF.	UNIT	QUANTITY	UNIT PRICE
1.	Re-mounting of Viking Cives PL1314LW-AL 13' x 8' U-Body Combination Dump/Spreader Body Aluminum, 12' reversible snow plow mounting hardware and all associated equipment on a 58,000# GVWR Conventional Cab & Chassis	16017	Each	5	

Name of Bidder

FORM N (R1): DETAILED SPECIFICATIONS 16017

RE-MOUNTING OF VIKING CIVES PL1314LW-AL 13' X 8' ALUMINUM U-BODY COMBINATION DUMP/SPREADER BODY, 12' REVERSIBLE SNOW PLOW AND ALL ASSOCIATED EQUIPMENT ON A 58,000# GVWR CONVENTIONAL CAB & CHASSIS

1.0 SCOPE OF WORK

- 1.1 These specifications describe the remounting/transfer of Viking Cives PL1314LW-AL 13' x 8' Dump/Spreader Bodies, 12' reversible snow plow mounting hardware and **all associated equipment** on to six (6) new 2017 Navistar 7500 SBA conventional chassis provided by the City of Winnipeg. The successful bidder is responsible for ensuring all installation requirements meet the chassis manufacture body mounting standards and all applicable Canadian Safety Standards. It will be the responsibility of the installer to ensure the final completion of the trucks meets all necessary operational performance requirements, chassis GVWR restrictions, weight distributions and center of gravity requirements. It is the intent of the City of Winnipeg to re-mount existing Dump/Spreader Bodies, 12' reversible snow plows and all associated equipment and assess a new 7-9 year life cycle on the sander spreader bodies, plows and new truck chassis.
- 1.2 The re-mounting of all equipment shall be furnished complete and ready for operation. **Any parts or accessories not specifically mentioned, but which are required to complete and place the equipment and associated attachments in successful operation shall be furnished as though specifically mentioned in these specifications.** The equipment and associated and attachments, and all parts thereof, shall conform in strength and quality of material and workmanship, to the best standards and engineering practice of the industry.
- 1.3 Bidders are encouraged to view the Viking Cives PL1314LW-AL 13' x 8' Dump/Spreader Bodies prior to submitting a bid. To make an appointment to view the units, contact the Contract Administrator in D4.

2.0 ADDITIONAL WORK

- 2.1 The items outlined in **7.0 Scope of Work** are for award purposes only and shall not be construed to describe the complete work required. Additional work may be required to bring the sander spreader bodies to "as new" condition and shall be performed by the Contractor on a cost plus basis.
- 2.2 Prior to commencement of additional work, the Contractor shall submit a written quotation for the work to be performed, for approval by the Contract Administrator. The written proposal shall consist of a detailed description of the work to be performed, materials required, material costs, hourly shop charge and the total number of shop hours required. The hourly shop charge shall include all applicable local taxes, shop supply fees, etc. Upon re-mounting installation should the contractor identify equipment components that would not meet a 7-9 year life cycle, the Contractor shall contact the Contract Administrator with a parts and labour quote prior to the any work being completed. Additional work, not described in these specifications, but which is required to complete the transfers to an "as new" condition, shall be performed on a cost plus basis.

2.0 OTHER SPECIFICATIONS AND STANDARDS

- 2.1 All applicable SAE standards form an integral part of these specifications and shall have precedence in any conflict concerning minimum acceptable standards.
- 2.2 The **Remounting Dump/Spreader Bodies and attachments** shall comply with the applicable regulations:
- National Safety Mark, NSM
 - Manitoba Safety and Health Act, Parts 12, 22
 - Canadian Standards Association, CSA
 - Under Writers of Canada, U/L

- Society of Automotive Engineers, SAE
- City of Winnipeg Lighting Visibility Standard=<http://winnipeg.ca/matmgt/pdfs/PublicWorksEquipLightingVisibility.pdf>.

2.3 **It will be the responsibility of the Bidder to inform the City of any deficiencies in these specifications, for under this Contract the Contractor shall be held responsible for the design, performance, reliability and satisfactory operational function of the units.**

3.0 SERVICE FACILITY

3.1 For the purpose of warranty repair and chassis logistics, the Bidder shall have an authorized service facility located within 10 km of the boundaries of the City of Winnipeg. The facility, or a portion thereof, shall be dedicated to the service, maintenance and equipment re-mounting of the type equipment being installed. Bidders shall provide a description of the service facility including, but not limited to, number of qualified service staff, years of service experience, and general service, maintenance and installation capabilities within three (3) Business Days upon request of the Contract Administrator.

4.0 PERFORMANCE RELIABILITY

4.1 The responsibility for the re-mounting of the **Dump/Spreader Bodies and associated attachments**, its performance and reliability shall rest upon the Contractor.

4.2 The term "repeated failures" as used herein is defined to mean that the same component, subassembly, or assembly develops repeated defects, breakdowns and/or malfunctions rendering the vehicle inoperative, or requiring repeated shop correction, service and/or replacement during the warranty period applicable for said component, subassembly, or assembly. Minor items or ordinary service adjustments are not included, or considered under the scope of "repeated failures", as well as other factors, such as operational damage due to accidents, misuse or lack of proper maintenance, service and lubrication attention by not following the manufacturer's preventative maintenance schedule.

4.3 **The equipment shall be capable of consistent top performance in City of Winnipeg Environment. Note: The City of Winnipeg has four seasons with ambient temperatures ranging from approximately 90°F (32°C) to -40°F (-40°C)**

5.0 QUALIFICATIONS OF CONTRACTOR

5.1 The Contractor of the re-mounting of the sander spreader bodies and all associated equipment shall have five (5) years continuous experience installing **U-Body Combination Dump/Spreader Bodies and associated attachments**.

5.2 The success bidder shall have in effect a documented quality control program ensuring that the quality of materials and workmanship, including welding, conforms to the best standards and engineering practice of the industry.

5.3 The Contractor shall have five (5) years continuous experience servicing, repairing and maintaining **U-Body Combination Bodies and associated attachments** of the type being offered.

6.0 NATIONAL SAFETY MARK

6.1 In Canada, modification to new vehicles can only be done at facilities that are recognized by Transport Canada. All of these facilities must have a National Safety Mark from Transport Canada. Transport Canada National Safety Mark is a label that indicates that the modifications are compliant with all current Canadian Motor Vehicle Safety Standards (CMVSS)

STATE (NSM) # - _____

SPECIFICATION 16017

RE-MOUNTING OF VIKING CIVES PL1314LW-AL 13' X 8' ALUMINUM U-BODY COMBINATION DUMP/SPREADER BODY, 12' REVERSIBLE SNOW PLOW AND ALL ASSOCIATED EQUIPMENT ON A 58,000# GVWR CONVENTIONAL CAB & CHASSIS

7.0 SCOPE OF WORK

- 7.1 The bidder shall Complete equipment assessment and report to the Contract Administrator on a unit #, Viking E# and serial # basis.
- 7.2 Chemical Wash of the entire exterior body
- 7.3 New painted black wood planks.
- 7.4 New poly half-moon brackets and fenders.
- 7.5 New hydraulics hoses (where applicable) and all fittings
- 7.6 Transfer existing Parker controls.
- 7.7 Re-mount, sand blast and paint, front hitch plates
- 7.8 All Controller Wiring, harness or fittings on a need basis only
- 7.9 Replace all hydraulic oil and filters,
- 7.10 Replace pressure filter element.
- 7.11 Change oil in the gear box
- 7.12 Front pump new drive shaft only
- 7.13 Chains replaced with new
- 7.14 New Sprockets, shafts and idler shafts.
- 7.15 New Wiring harness (description)
- 7.16 New junction box on a need basis only.
- 7.17 Tail gate air trip requires reconnection to a dash switch on the new chassis
- 7.18 Thorough inspection of liquid pumping systems, pumps and sensors
- 7.19 Supply & Install items on parts list below
- 7.20 Re-mounting CPL Greasing Systems- contact Glen Taylor Regional Account Manager Manitoba & North West Ontario Groeneveld - CPL Systems Canada E: g.taylor@groeneveld-group.com C: 204-771-8910 O: 1-800-263-1760 W: www.groeneveld-lubrication-solutions.com or Lubecore Manitoba- contact David Goodwill C: 204-430-0333 W: <http://lubecore.com/>.
- 7.21 New rear hitch plate and re-mount the pintle hook.
- 7.22 Inspect box liners and report
- 7.23 Bidder shall state all Part warranties and parts as per below.

Item Number	Item Description	Quantity	Part #	Part Warranty
DWG F	Front mounting pump install plate	1	01900436	State
DWG D # 3 & 4	Front push plate tail plate kit	1	00300863	State
DWG C # 2	Front hoist mount saddle	1	01304062	State
DWG C # 3	Box guide	2	01918001	State
DWG C # 17	Dump hinge with body prop assembly	1	01324217	State
DWG A # 4	Main conveyor chain	1	0600050	State
DWG B #55	4 bolt flange bearing	4	0610042	State
DWG B #56	8 tooth sprocket	4	0600048	State
DWG B #60	2 x 31.25 idle shaft	1	01324160	State
DWG B #54	2 x 34.625 drive shaft	1	01324161	State

DWG B #68	1.5 x 30 tensioning shaft	1	01324159	State
DWG B #107	Idler roller	2	01324191	State
DWG B #86	Tension spring	2	0580035	State
DWG A #10	Main drive rebuild kit	1	01323225	State
DWG E	Electrical main harness replacement	1	0650249	State
Hydraulic hose	2-Wire Braided Construction. Exceeds EN857 Type 2SC requirements. Exceeds SAE 100R16 Type S requirements. Dura-Tuff abrasion resistant cover w/ 1/2 SAE minimum bend radius.	All new (no exceptions)		State

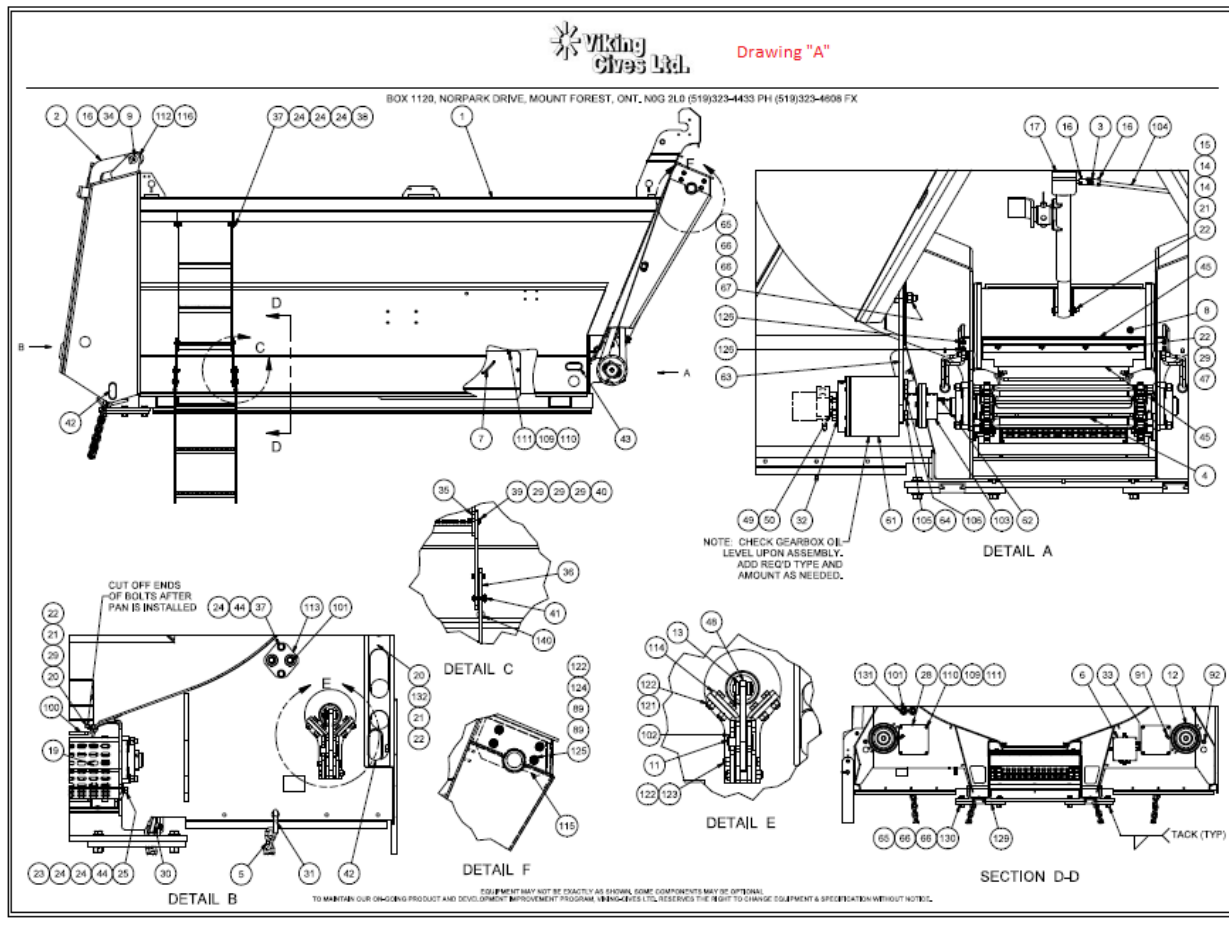

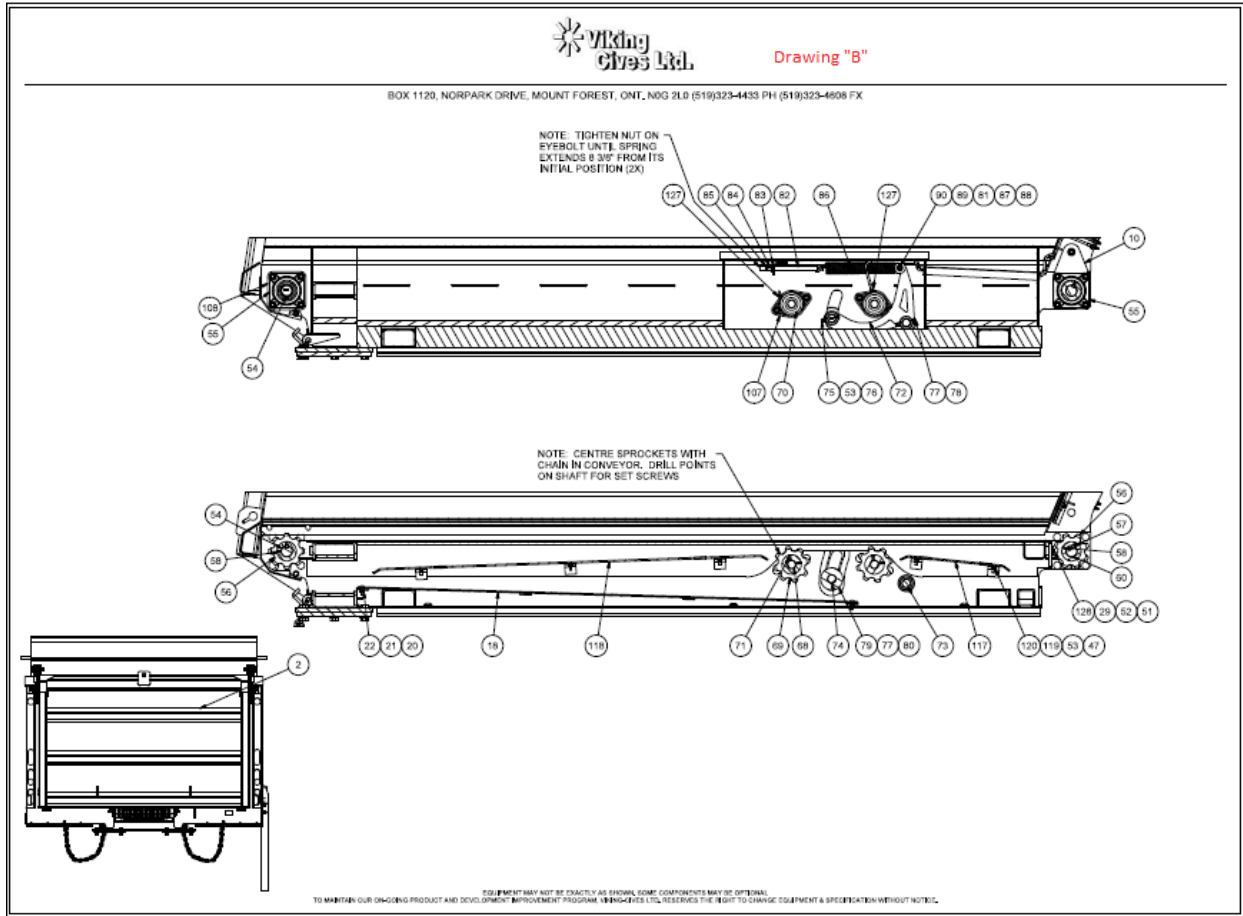

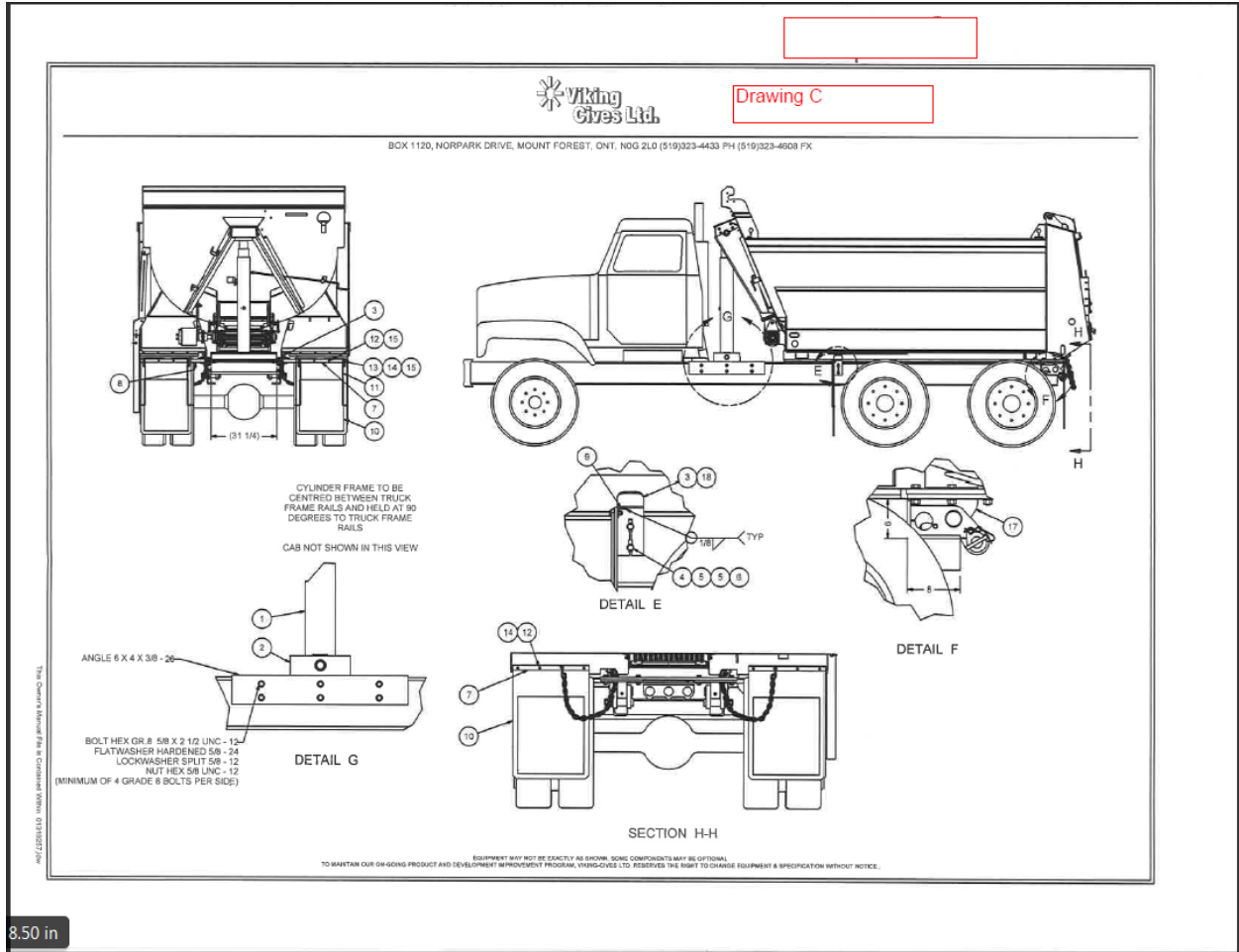

8.50 in

Drawing "D"

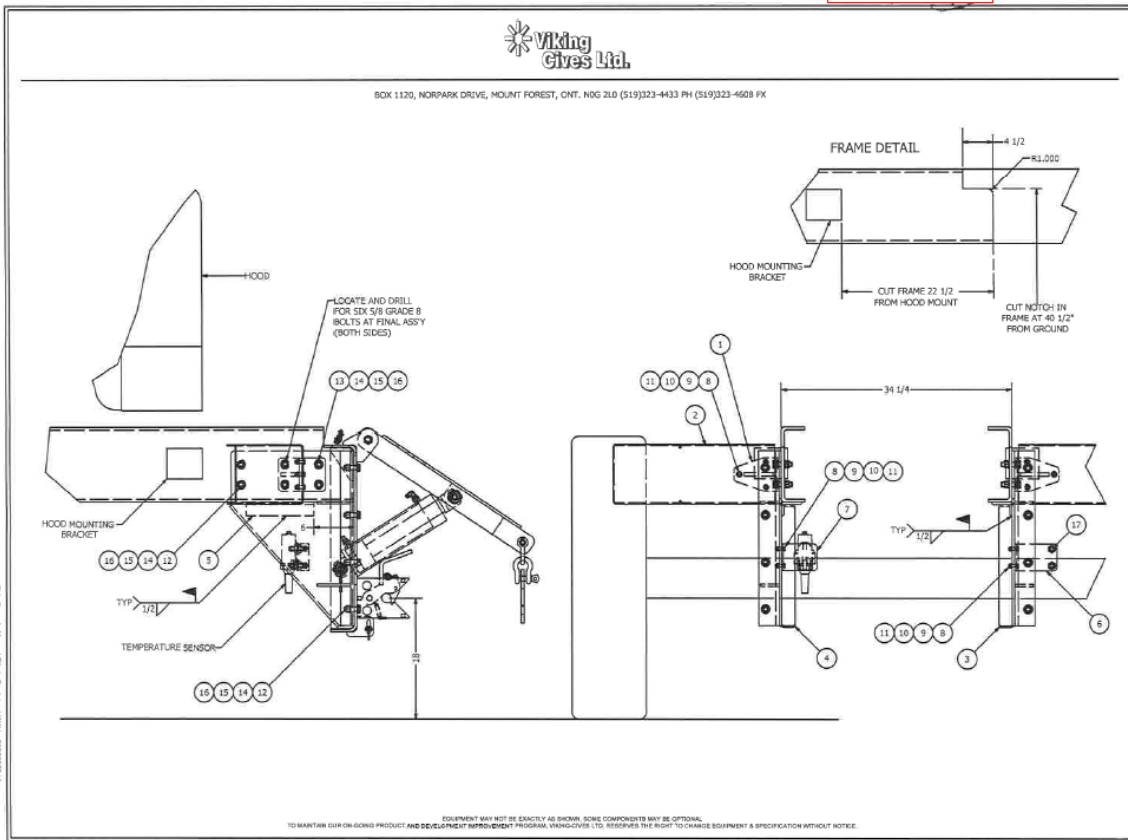

3.50 in

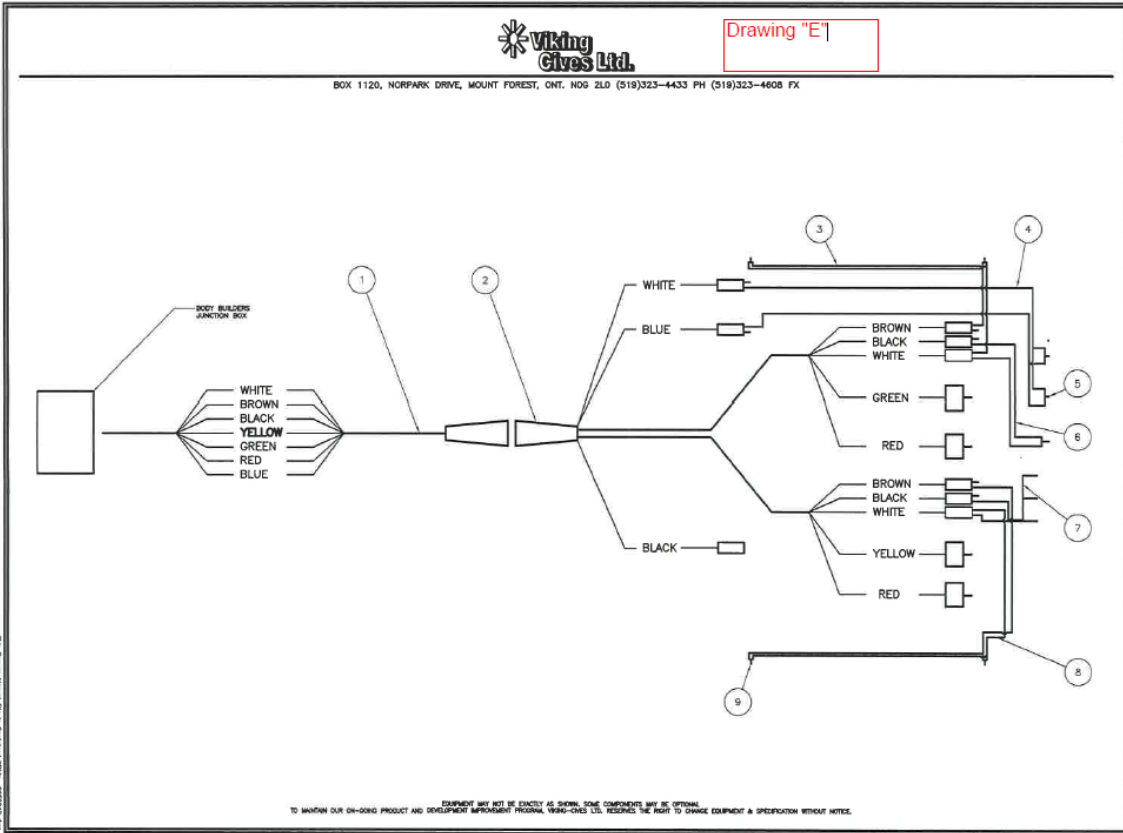

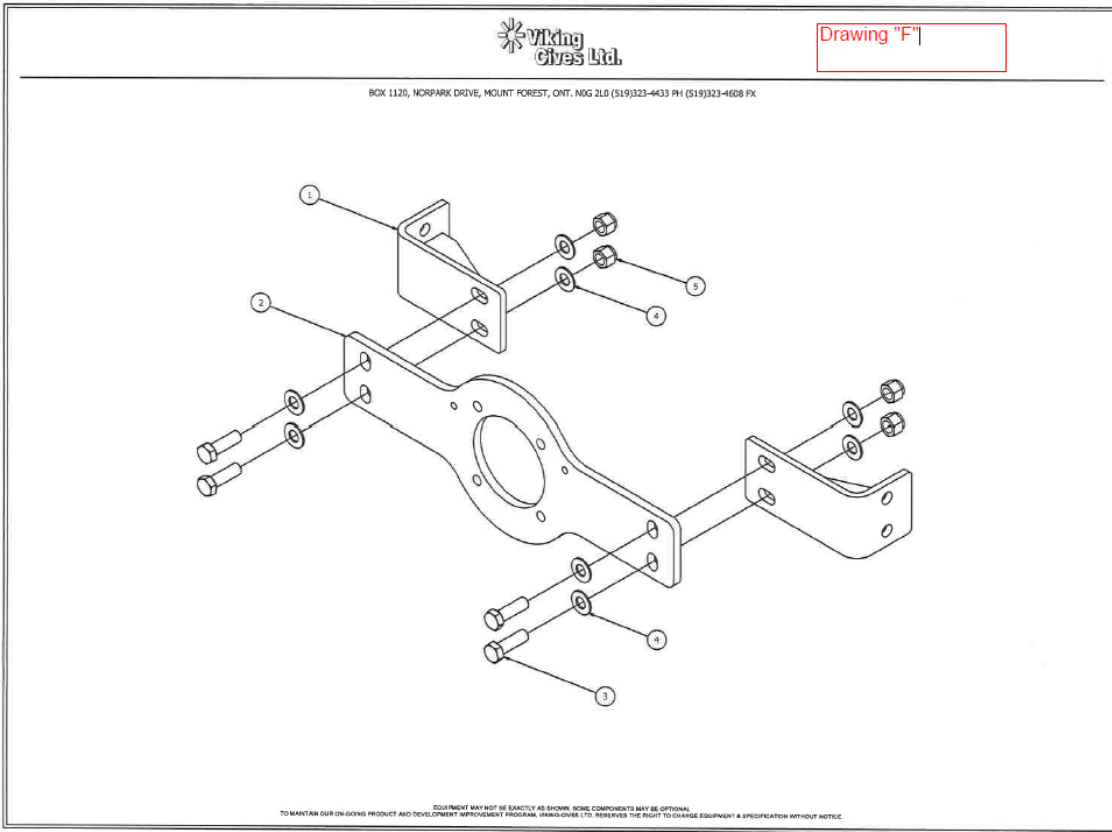

8.0 INSTALLATION

- 8.1 The equipment installation shall meet all Canadian Safety Standards applicable to this type of equipment _____
- 8.2 Any holes required in the chassis frame web must be drilled and reamed to fit bolts. _____
- 8.3 Drilling on chassis frame flanges is not permitted. _____
- 8.4 Welding on the chassis frame is not permitted with the exception of installation of dump body pivot support. _____
- 8.5 Tire clearance – approx. 4 in. plus full suspension deflection. _____

9.0 FINISH

- 9.1 All steel components that require re-painting shall be sandblasted, properly cleaned, primed and finished as follows: (Note: stainless steel and aluminum components shall remain unfinished). _____
- 9.2 Front and rear hitch plates with accessories, hydraulic oil reservoir and valve enclosure, and underside of floor (steel) shall be primed with Endura EP32 Intermix Epoxy Primer then finished with 3-5 mils black Endura EX-2C Topcoat. (Inside of steel floor excluded). _____
- 9.3 All unprotected components in the valve enclosure, including the interior of the enclosure shall be primed with a suitable primer. _____

10.0 WEIGHT DISTRIBUTION

- 10.1 The completed units and all associated components shall not exceed the City of Winnipeg's limit for gross vehicle weight, axle and tire loads with the unit (including the chassis) fully fuelled and operational, full liquid tank, one (1) operator, and including a full payload (struck capacity) of dry sand. _____

11.0 PARTS WARRANTY

- 11.1 One year warranty, unlimited hours _____
- 11.2 All warranty information shall be detailed and include all exclusions. The successful bidder shall provide all published warranty information upon delivery of the equipment. Bidder shall state all warranty information. _____

12.0 DELIVERY SCHEDULE

- 12.1 The City of Winnipeg Fleet Management Agency requires re-mounts to be completed as per Appendix A commencing September 15, 2017. _____

CHASSIS CLASS 8 54000 GVW TANDEM	2908405
CHASSIS CLASS 8 54000 GVW TANDEM	2908406
CHASSIS CLASS 8 54000 GVW TANDEM	2908418
CHASSIS CLASS 8 54000 GVW TANDEM	2908423
CHASSIS CLASS 8 54000 GVW TANDEM	2908424

12.2 **Delivery Point:** The complete units shall be serviced, ready for operation and delivered F.O.B. with the freight prepaid, including invoice and N.I.V.S. (if applicable) to the WFMA 185 Tecumseh Street, Winnipeg MB. The successful Bidder shall be notified by the Contractor Administrator the delivery address prior to issuance of the purchase order.

12.3 **Delivery Time:** Equipment shall be delivered between 8:00 am and 2:00 pm on Business Days.

12.4 **Delivery Contact:** The Contractor shall contact the Contract Administrator prior to delivery of the equipment.

12.5 **P.D.I.:** A pre-delivery inspection shall be performed by the Contractor on the equipment. Proof upon inspection including completed check list
